

## PRODUCT DATASHEET

### HFW-MA-05

## WIRELESS (LIBRA) MULTI-CRITERIA DETECTOR

The HFW-MA-05 is the latest in wireless multi-criteria detector technology. It is a fully intelligent device and compatible with all Hyfire wireless Translator and Expander modules. The detector is designed for open area protection and combines both dual-path smoke and heat detection technologies for improved performance, whilst maintaining the high levels of unwanted alarm rejection. Utilising well-proven adaptive radio signal processing algorithms ensures that the highest levels of life safety and system reliability are achieved. An in-built magnet test allows easy activation to verify correct functionality and response.

\*For BASE COMPATIBILITY see page 3



### KEY FEATURES

- Advanced dual-path optical chamber design
- Internal algorithm processing optimises performance
- 3rd party approved
- Up to 10 year battery life
- Utilises standard low cost lithium battery technology
- Multiple smoke and heat sensitivity settings
- Bi-directional wireless communications
- Compatible with all Hyfire translators and Expanders
- Complies with the latest multi-sensor standard EN 54-29
- 5 year product warranty
- Device identification tab
- Twin alarm LEDs for 360° visibility

### TECHNICAL INFORMATION

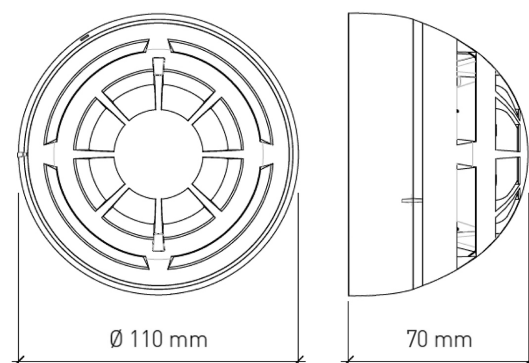

### TECHNICAL SPECIFICATION

■ Operating frequency range	868 – 870 MHz
■ Max. radiated power	14dBm (25mW)
■ Operating channels	Multiple
■ Choice of sensitivity settings	3 smoke/2 heat
■ Dimensions	110mm x 70mm
■ Batteries	2 x CR123A
■ Weight	190g
■ Temperature Range (no icing)	-10°C to +55°C **
■ Max tolerated humidity (non condensing)	95% RH
■ IP Rating	40
■ Magnet test	Yes

\*\*Performance may vary at extremes of range

### STANDARDS & APPROVALS

- BS EN 54-5 Class P: Heat Detectors
- BS EN 54-7 Smoke Detectors
- BS EN54-25: Components using radio links
- BS EN54-29: Multi-sensor fire detectors
- CEA4021



0832



928m

## LED INDICATION

The device is equipped with 2 tri-colour LEDs (red/green/amber) that provide visual indication for functional conditions and battery levels as indicated in the sections below:

## OPERATIONAL STATUS INDICATIONS

Status	Amber LED	Green LED	Red LED
Power Up	-	1 Second On then	4 x 0.5 Seconds On
Linking to System	-	Blinking until link is complete	-
Link Procedure has Failed	-	-	Continuous
Normal condition	-	-	-
Alarm condition	-	-	0.5 Second On & 0.5 Second Off
Main battery fault	0.1 Second On & 5 Seconds Off	-	-
Secondary battery fault	-	0.1 Second On & 5 Seconds Off	-
Both batteries fault	0.1 Second On & 5 Seconds Off	0.1 Second On & 5 Seconds Off	-
Other Fault	Sequential bi-colour flashing		-
Tamper	-	-	-
Loss of radio link with Translator/ Expander	-	-	-

## PRODUCT DATASHEET : HFW-MA-05

### COMMUNICATION QUALITY ASSESSMENT

It is possible to assess the wireless communication quality between the device and translator or expander using the built in test facility. After successful programming of the device, changing the “Program” switch to the “ON” position will set the device into test mode and the LED will start blinking according to the table below:

Communication Quality (dB)	Level	Green LED	Red LED
No connection	Fail	-	Two flashes
Link margin is less than 10 dB	Poor - not acceptable	-	One flash
Communication with link margin from 10 dB to 20 dB	Medium/Low - not recommended	One flash	-
Communication with link margin from 20 dB to 30 dB	Good	Two flashes	-
Robust communication with link margin over 30 dB	Excellent	Two flashes	-

Note: The “program” switch must be returned to the 1 position for normal device operation

### BASE COMPATIBILITY

This device is supplied with a standard base and is compatible with the following Hyfire base sounders:

- HFW-BS-05      Wireless Sounder Base
- HFW-BSB-05    Wireless Sounder Base Visual Indicator

