

DATASHEET

WIRELESS SINGLE CHANNEL INPUT MODULE

HFW-IM-03

The Hyfire HFW-IM-03 Wireless Module has been designed to provide a convenient and cost effective solution for monitoring third party equipment. The unit has a single fully monitored input circuit which allows simple integration of third party equipment with the fire system. The unit is fully compatible with all Hyfire Translator and Expander modules and the well proven adaptive radio signal processing algorithms ensure the highest levels of life safety and system reliability.



KEY FEATURES

- 3rd party approval to EN54-25 & EN54-18
- 5 year product warranty
- 5 year expected battery life
- Self optimising wireless frequency and amplitude algorithms
- Bi Directional wireless communication
- Fully intelligent
- Input circuits are fully monitored for alarm and fault conditions
- Utilises dual low cost lithium battery

TECHNICAL INFORMATION

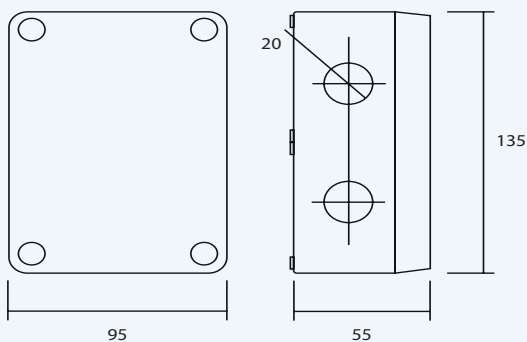

TECHNICAL SPECIFICATION

Operating frequency range	868 - 870 MHz
Max radiated power	5dBm (3mW)
Radio signal modulation type	FSK
Operating frequency channels	7
Communication range with the translator or the expander	≤ 150 m (in open space)
Max humidity (non condensing)	95% RH
Cable entry knockout holes	6 x M16/20
Applicable wire gauge range	0.5 mm ² to 2.5 mm ²
Weight (without batteries)	190 g
Primary battery	CR123A (3 V & 1.2 Ah)
Secondary battery	CR2032 (3 V & 0.24 Ah)
Operating temperature range (no icing)	-10°C - +55°C

STANDARDS & APPROVALS

BS EN 54-25:
Components using radio links and system requirements
BS EN 54-18:
Input/Output Devices

