

QUICK START GUIDE

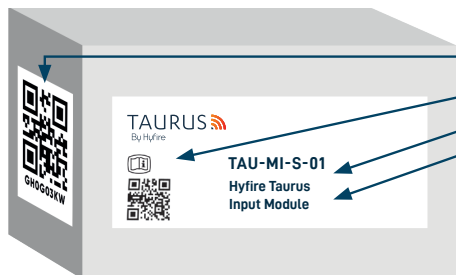

THE BOX

- Taurus QR code
- Manual QR code
- Product code
- Product name

INSIDE THE BOX

- 1 x Input Module
- 2 x CR123A batteries
- Batteries not included for item code TAU-MI-S-01/NB
- 4 x Securing screws
- 1 x Resistor pack
- 1 x Quick start guide
- 1 x QR code

MOUNTING STEPS

The Input Module is designed to meet IP65 rating, suitable for external mounting. Proceed as follows to complete the device installation.

Available also without batteries: TAU-MI-S-01/NB



IMPORTANT TO CONSIDER

When mounting a wireless device a comprehensive radio survey should have been carried out to establish the location that provides the best coverage and optimum reach. Taking into consideration the building structure and materials, the survey identifies the wireless infrastructure required and product locations for optimum performance, identifying any factor that could prevent radio integrity.

Avoid fixing or mounting the unit close to the following:

- Equipment that utilises large electrical currents
- Large metal objects or structures
- Fluorescent lighting fittings
- Metal ceiling structures
- IT cabling.

Keep 2 meters minimum spacing between other wireless equipment in the area to avoid signal interference.



EN54 approved environmental temperature range is -10°C to +55°C

UNBOXING

- When unboxing the input module you will find the unit and its lid.
- This comes with pre-formed mounting holes to drill out and mount the backbox.
- Securing screws are supplied for the lid.
- A resistor pack is supplied for the monitored connection (10KΩ R_{EOL} and 5.6KΩ R_{AL}).

For more information, please refer to the complete product manual.

1

Remove the lid from the back box, removing the screws on the corners.

2

- Remove the appropriate knock out on the underside or lower rear of the casing, install the M16/20 IP rated gland.
- Note: pay attention to avoid damages to the PCB, while removing the knock out, or remove it before starting.

3

- To retain IP rating, please ensure you use the outer holes on the casing.
- Using a pencil, mark through the outer holes on the desired surface you will attach the unit to.
- Using a suitable-sized drill bit (6 mm) drill the marked screw points on your chosen surface.
- Ensure you use the correct fixings for the type of surface you are mounting to.
- Screw the backbox to the desired surface using all fixing holes and appropriate-sized roundhead screws (not countersunk).

4

DIP SWITCH
LED
BATTERY COMPARTMENTS

- Ensure the switch on the PCB is in position ON.
- Fit the 2x CR123A batteries ensuring you have checked they are the correct way round observing the polarity indications on the PCB.
- The LED will signal 4 times red.
- Move the switch on the PCB to position 1. The LED will blink few seconds green and then signal alternatively green/red 4 times.

ELECTRICAL SCHEME FOR THE CONNECTION OF THE INPUT MODULE TO THE EXTERNAL DEVICE WHICH TRANSMITS THE INPUT SIGNAL TO THE MODULE

5

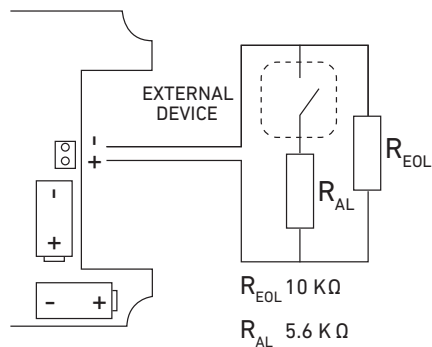

- The $10\text{K}\Omega$ R_{EOL} resistor monitors whether the cable has been damaged or the connection is no longer available.
- The $5.6\text{K}\Omega$ R_{AL} resistor comes in and out of circuit depending on the state of the 3rd party device (alarm resistor).
- If you fail to install these resistors correctly the device will not operate as intended.
- Ensure the 3rd party device offers a voltage free relay switch.

Note: install a properly fire rated cable (according to national code of practice) between the third-party device and the input module.

6

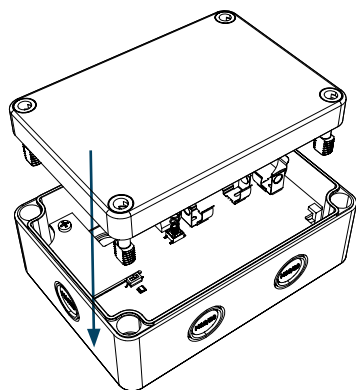

- Refit the lid to the back box, using the supplied screws.
- Put the QR code available in the box either on the system map or on the dedicated pages at the end of translator or expander manual.