

DATASHEET  
**HYFIRE TAURUS**  
**MULTI-SENSOR DETECTOR**  
TAU-MC-01

**TAURUS**   
By Hyfire

The TAU-MC-01 Hyfire Taurus Multi-sensor Detector is the latest in wireless multi-sensor detector technology. The detector is a fully intelligent device combining both dual optical smoke and heat detection technologies for improved performance, whilst maintaining high levels of unwanted alarm rejection. Utilising well-proven adaptive radio signal processing algorithms ensure the highest levels of life safety and system reliability are achieved. An in-built magnet test allows easy activation to verify correct functionality and response.



### KEY FEATURES

- Advanced dual optical chamber design
- Twin alarm LEDs for 360° visibility
- Multiple operating settings
- Advanced drift compensation
- Bi-directional wireless communication
- Can be used with Taurus addressable and conventional translators
- 22 pairs of field channels
- Dual channel redundancy
- Long communication range ( $\cong$ 1 km in open air)
- 10 year battery life
- Utilises standard low cost lithium battery technology
- Device identification tab
- Security screw to prevent tampering and unwanted removal
- Easy scan & link programming option
- 3rd party approval to EN54-5, EN54-7 and EN54-25
- 5 year product warranty
- Tri-coloured LED

### TECHNICAL SPECIFICATION

Operating frequency range	868 – 870 MHz
Max radiated power	14dBm (25mW)
Dimensions	110mm x 70mm
Weight (without batteries)	155 g
Batteries	2x CR123A
Operating Temperature	-10°C to +55°C
Max humidity (non condensing)	95% RH
IP rating	40

### TECHNICAL INFORMATION

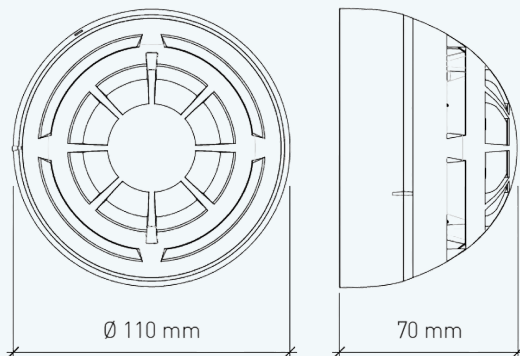

### STANDARDS & APPROVALS

- BS EN54-5 Class A1R: Heat Detectors
- BS EN54-7 Smoke Detectors
- BS EN54-25: Components using radio links



DATASHEET  
**HYFIRE TAURUS**  
**MULTI-SENSOR DETECTOR**

**TAURUS**   
By Hyfire

### BASE COMPATIBILITY

---

This device is supplied with a standard base and is compatible with the following sounder bases:

- TAU-BS-01 Hyfire Taurus Sounder Base
- TAU-BSB-23W-01 Hyfire Taurus Sounder VAD Base (White Flash) (EN54-23 approved)
- TAU-BSB-23R-01 Hyfire Taurus Sounder VAD Base (Red Flash) (EN54-23 approved).

