

DATASHEET

HYFIRE TAURUS

OUTPUT MODULE

TAU-MO-SB-01

TAURUS 
By Hyfire

The TAU-MO-SB-01 Hyfire Taurus Output Module has been designed to allow easy control of a variety of third party equipment including access control doors, ventilation plant and fire extinguishing systems. The unit is powered entirely from its internal battery supply and is fitted as standard with both a set of change over relay contacts and a 12/24V dc output. The output is capable of supplying power for operating low current third party equipment directly from the internal batteries.



KEY FEATURES

- Bi directional wireless communication
- Output circuits are fully supervised for fault conditions (utilizing EOL resistors)
- Can be used with Taurus addressable and conventional translators
- Change over relay and 12/24V output functionality
- On site programmable
- 22 pairs of field channels
- Dual channel redundancy
- Long communication range (\cong 1 km in open air)
- 5 year expected battery life (application dependent)
- Utilises dual low cost lithium battery
- Easy scan & link programming option
- 3rd party approval to EN54-18 and EN54-25
- 5 year product warranty

TECHNICAL SPECIFICATION

Operating frequency range	868 – 870 MHz
Max radiated power	14dBm (25mW)
IP rating	65
Weight (without batteries)	233 g
Primary & Secondary batteries	CR123A (3 V & 1.2 Ah)
Dimensions	136 x 96 x 57 mm
Relay Specifications	2A @ 30V DC
Operating Temperature	-10°C to +55°C
Max humidity (non condensing)	95% RH
Maximum Current Available	100mA @ 12V dc 50mA @ 24V dc
EOL Supervision Resistor	10K

TECHNICAL INFORMATION

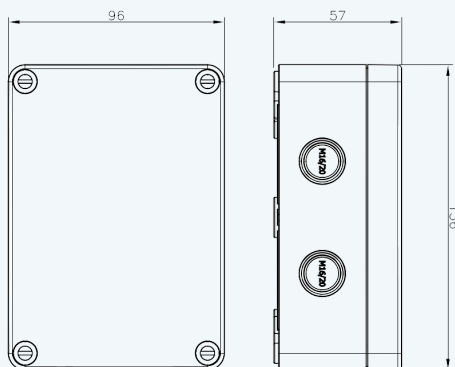

STANDARDS & APPROVALS

- BS EN54-18: Input / Output Devices
- BS EN54-25: Components using radio links and system requirements



DATASHEET
HYFIRE TAURUS
OUTPUT MODULE

CONNECTIONS AND CONFIGURATIONS

Wiring example for 100mA/12 VDC or 50 mA/24 VDC external device driving capability

Wiring example for the relay switch output.

