

DATASHEET

HYFIRE TRI-SENSOR DETECTOR

HFW-TRI-05



The Tri-Sensor Detector (CO, smoke, heat) is the latest in wireless multi-criteria detection technology. It is a fully intelligent device and compatible with the Static wireless translator and expander modules.

The detector combines CO sensing, dual-path smoke and heat detection technologies for unrivalled performance, maintaining high levels of unwanted alarm rejection. The device complies with EN54-31 (point detectors using a combination of smoke, carbon monoxide and optionally heat sensors) which considers two possible MT and NT operative modes. The MT mode requires at least two independent stimuli (eg smoke & CO, thermal & smoke) to get to a full alarm, whilst the NT operative mode allows a full alarm to be generated from a single stimulus. Our device offers various possible environmental profiles for each of the two modes, further improving nuisance rejection and guaranteeing the promptest fire detection.



KEY FEATURES

- Dual angle scattering analysis optical chamber design
- Solid electrolyte carbon monoxide sensor (10 years life)
- Internal algorithm processing optimises performance
- 12 profiles available, from harsh/industrial to ultra-clean environments
- Utilises standard low cost lithium battery technology
- 8 year battery life
- Bi-directional communication protocol between all wireless devices
- Device identification tab
- Fast magnet test feature for engineer testing
- Twin alarm LEDs for 360° visibility
- Approved to EN54-5, EN54-7, EN54-31 and EN54-25.

TECHNICAL INFORMATION

Operating frequency range	868 MHz
Maximum radiated power	14dBm (25mW)
Operating frequency channels	Multiple
Choice of sensitivity settings	Modes MT & NT
Dimensions (H x W)	110 x 70 mm
Weight	200 g
Batteries	2xCR123A
Operating temperature range	-10°C to +55°C
Maximum tolerated humidity (non condensing)	95% RH
IP rating	40
Magnet test	Yes
Solid electrolyte cell life	10 years

TECHNICAL SPECIFICATION

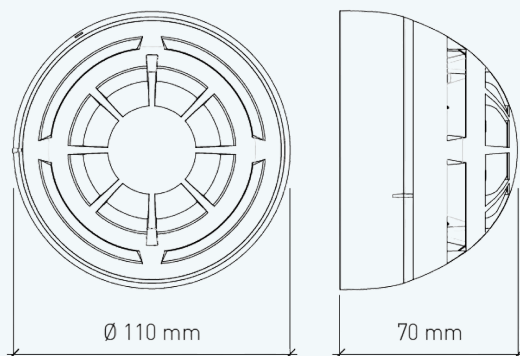

STANDARDS & APPROVALS

- EN54-5 Heat Detectors - Point Detectors
- EN54-7: Smoke Detectors - Point Detectors using scattered light, transmitted light or ionisation
- EN54-31: Multi-sensor fire detectors - point detectors using a combination of smoke, carbon monoxide and optionally heat sensors
- EN54-25: Components using radio links and system requirements