

DATASHEET
HYFIRE TAURUS
BLACK HEAT DETECTOR
TAU-TH-01-BL

TAURUS 
By Hyfire

The TAU-TH-01-BL Hyfire Taurus Black Heat Detector is the latest in wireless heat detector technology. The detector is a fully intelligent device designed to give the best possible warning of a fire condition in locations where smoke detection technology is not suitable. The device is capable of being configured as either a high temperature or rate of rise device type. The well-proven adaptive radio signal processing algorithms ensure the highest levels of life safety and system reliability are achieved. An in-built magnet test allows easy activation to verify correct functionality and response.



KEY FEATURES

- Twin alarm LEDs for 360° visibility
- Programmable for rate of rise (A1R) or high temperature (BS)
- Bi-directional wireless communication
- Can be used with Taurus addressable and conventional translators
- 22 pairs of field channels
- Dual channel redundancy
- Long communication range (\cong 1 km in open air)
- 10 year battery life
- Utilises standard low cost lithium battery technology
- Device identification tab
- Security screw to prevent tampering and unwanted removal
- Easy scan & link programming option
- 3rd party approval to EN54-5 and EN54-25
- 5 year product warranty
- Tri-colour LED

TECHNICAL SPECIFICATION

| | |
|-------------------------------|---------------------------------------------|
| Operating frequency range | 868 – 870 MHz |
| Max radiated power | 14dBm (25mW) |
| Class | A1R (58°C max) or Class BS high temp (78°C) |
| Dimensions | 110mm x 70mm |
| Weight (without batteries) | 153 g |
| Batteries | 2x CR123A |
| Operating Temperature | -10°C to +55°C |
| Max humidity (non condensing) | 95% RH |
| IP rating | 40 |

TECHNICAL INFORMATION

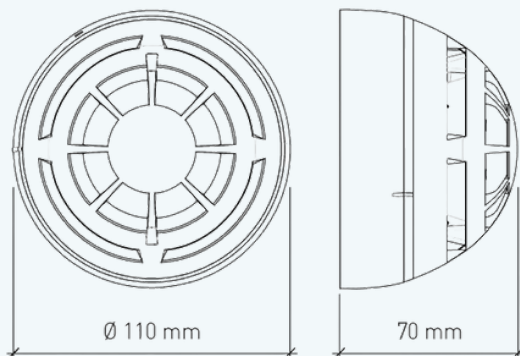

STANDARDS & APPROVALS

- BS EN54-5 Class P: Heat Detectors. Point Detectors
- BS EN54-25: Components using radio links



DATASHEET
HYFIRE TAURUS
BLACK HEAT DETECTOR

TAURUS 
By Hyfire

BASE COMPATIBILITY

This device is supplied with a standard base and is compatible with the following sounder bases:

- TAU-BS-01-BL Hyfire Taurus Black Sounder Base
- TAU-BSB-23W-01-BL Hyfire Taurus Black Sounder VAD Base (White Flash) (EN54-23 approved)

